

So you think your arsenal of books on home-made weapons is just about complete . . . You've got how-to manuals on handguns, rifles, machine guns, and grenade launchers; CN gas, CS gas, and Mace; mantraps and booby traps. You've maybe even read up on different types of missiles. But you probably don't have a step-by-step guide to rearming the LAW. Originally developed in the mid-1960s for the U.S. Army, the M72 66mm Light Anti-tank Weapon is a veteran of many conflicts. Although it is now obsolete in its original form by virtue of improvements in tank armor, it is still available in inert, fired, or deactivated form on the surplus/collector/underground market and is surprisingly easy to rearm. This little manual describes how to do just that, providing illustrated, easy-to-follow instructions for disassembling, rebuilding, and rearming the weapon's internal firing components and constructing a suitable projectile. But be warned—this manual is *for information purposes only*.

A PALADIN PRESS BOOK
ISBN 0-87364-764-5

ISBN 0-87364-764-5

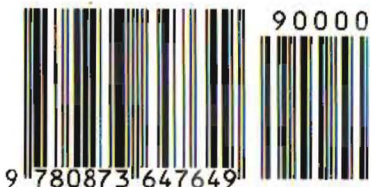

BROWN

LAW & DISORDER

LAW & DISORDER

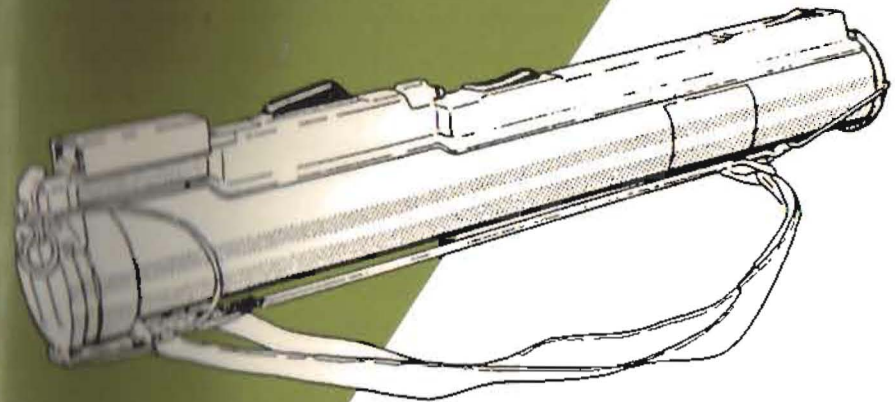

**Rearming the
66mm Light
Anti-Tank
Weapon**

Fred Brown

LAW and Disorder
Rearming the 66mm Light Anti-Tank Weapon
by Fred Brown

Copyright © 1994 by Fred Brown

ISBN 0-87364-764-5
Printed in the United States of America

Published by Paladin Press, a division of
Paladin Enterprises, Inc., P.O. Box 1307,
Boulder, Colorado 80306, USA.
(303) 443-7250

Direct inquiries and/or orders to the above address.

All rights reserved. Except for use in a review, no
portion of this book may be reproduced in any form
without the express written permission of the publisher.

Neither the author nor the publisher assumes
any responsibility for the use or misuse of
information contained in this book.



CONTENTS

INTRODUCTION: 1

PART ONE: Overview 3

PART TWO: Using the LAW 9

PART THREE: Rearming the LAW 23

APPENDIX: Warhead 47



INTRODUCTION

So, your arsenal of homemade weapons is almost complete. You've got handguns, rifles, machine guns, and grenade launchers; CN gas, CS gas, and Mace; mantraps and booby traps. You've maybe even knocked up a few missiles. But what about the LAW? No, not the guys who chased you last Saturday night, I'm talking about the Light Anti-tank Weapon, M72, 66mm type.

The LAW is available in inert, fired, or deactivated form on the surplus/collector/underground market and

is surprisingly easy to rearm. This little manual describes how to do just that, showing in illustrated, step-by-step form how to disassemble, rebuild, and rearm the weapon's internal firing components and construct a suitable projectile.

In the United States, surplus LAWs are likely to be found with the designations M72A1, M72A2, M72A3, and Practice Launcher M190. In Europe the same system is likely to be found with a designation such as RKT 66mm HEAT L1A2B1 or LNCHR & RKT 66mm HEAT L1A3B1.

Be warned. *This manual is for information purposes only.* You should never mess with propellants, projectiles, rocket launchers, igniters, explosives, raw fish, or poisonous toadstools without first checking with Mom and Dad that it is safe. Always wear gloves, goggles, safety boots, a hard hat, clean socks, and a tie. This ensures that if you do blow yourself up you will be smartly dressed for the funeral.

When dealing with improvised exploding things (IETs), it pays to check periodically for missing body parts, e.g., a finger. These bits are often the first to disappear when an experiment goes wrong. Count and make a note of the number of fingers you have now, for future reference.



PART ONE

OVERVIEW

Originally developed in the mid-1960s for the U.S. Army, the M72 66mm LAW is a veteran of many conflicts. Although it is now obsolete or obsolescent in its original form by virtue of the improvements in tank armor, an enhanced version (the M72E4/5/6 series, manufactured by the Talley Defense Systems/Raufoss consortium) is still in production at the time of this writing. The M72E4 has an armor-penetration capability of 355 millimeters. In the U.S. Army

the 84mm M136 (AT4) has taken over the role of the M72 LAW. The British army replacement (for the 66mm LAW and the 84mm Carl-Gustaf) is the 94mm LAW 80.

CONSTRUCTION

The M72 series 66mm LAWs are single-shot, fire-and-discard systems. Each unit consists of two concentric tubes. The outer tube is fiberglass and carries the rear sight cover, rear and front sight assemblies, safety handle, trigger housing, and trigger assembly.

The inner tube is of aluminum construction and is designed so as to slide telescopically along a channel assembly riding within an alignment slot in the trigger housing assembly. The channel assembly contains a firing-pin-rod system.

When the inner tube is extended, as for firing, the channel assembly locks it in the fully open position. The last inch or so of travel of the inner tube as it is extended causes the firing-pin-rod assembly to cock the weapon.

THE FIRING SYSTEM

The trigger takes the form of a rubber-covered bar, which must be depressed firmly to release the cocked firing-pin-rod assembly. This cannot be done until the safety handle is pulled out to the "arm" position. The firing-pin assembly is contained in a housing mounted on the top rear section of the innermost tube.

When the trigger is depressed the spring-loaded firing-pin rod is released and moves backward, causing the point of the firing "pin" to pass through a small horizontal exit slot and strike the primer. The pin is then withdrawn back into the housing.

The primer itself is contained within a primer block in the form of a cylindrical nylon insert mounted in the firing-pin housing. Attached to this block is a flash tube

that runs down to a propellant igniter in the base of the rocket itself. Upon firing, flame from the primer travels through the tube to the igniter, causing the rocket motor propellant to start burning.

THE ROCKET AND WARHEAD

A typical 66mm rocket comprises an M18 HEAT (High Explosive Anti-Tank) warhead, tetryl booster, M412 PIBD (Point Initiating, Base Detonating) fuze, and the M54 rocket motor. The design of this motor is such that all the propellant is burnt before the rocket leaves the tube. This technique is known by the acronym ABOL, derived from the phrase "All Burnt On Launch." Systems utilizing the ABOL principle do not require a blast/heat shield around the front of the tube as was common in early bazooka-type anti-tank launchers in which the rocket motor was still burning fiercely when the projectile left the tube.

It is perhaps worth noting here that systems such as the RPG-7 and its variants employ an alternate technique in which a small charge "kicks" the projectile out of the tube to a safe distance in front of the firer before the rocket engine proper starts its burn.

Attached to the nozzle of the LAW rocket are six spring-loaded fins. These are folded forward along the nozzle/motor section when the rocket is in the tube. Upon leaving the tube these fins spring out to stabilize the rocket in flight. Initial velocity of the rocket is around 158 meters per second (m/sec).

The HEAT warhead section of the rocket is of a tapering cylindrical design containing a shaped charge based around 3/4 pound of explosive (originally Octol) and a copper cone liner. Upon impact a piezo-electric crystal assembly in the PIBD fuze is crushed, causing an electrical current to be generated. The current travels along a connecting wire to the fuze, which explodes, detonating

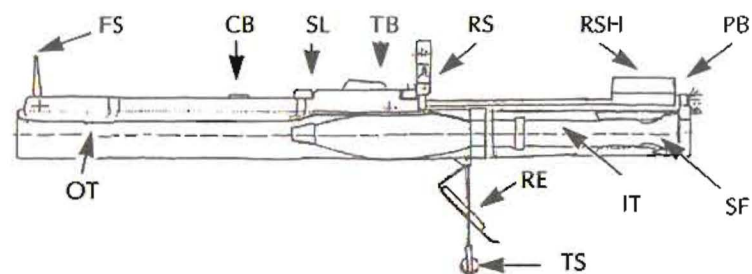

FIGURE 1: Cross section of the M72 66mm LAW system

IT	Inner tube	FS	Front sight
OT	Outer tube	TS	Transportation safety pins
RSH	Rear sight housing	RE	Rear end-cap
RS	Rear sight	CB	Close-down button
TB	Trigger bar	PB	Primer block housing
SL	Safety lever	SF	Spring-loaded fins (folded forward)

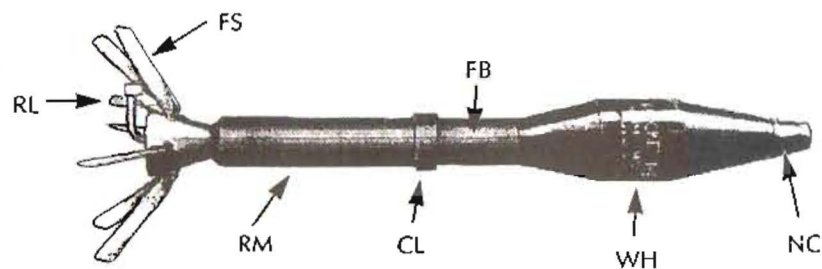

FIGURE 2: Exterior of the 66mm LAW rocket

WH	Warhead section (black with caliber and model designation, ammunition lot number, and type of warhead in yellow lettering)	RL	Round lock (transit safety)
NC	Nose cap	RM	Rocket motor housing (anodized aluminum)
CL	Closure	FB	Fuze and booster section (anodized aluminum)
		FS	Fins (6, spring-loaded)

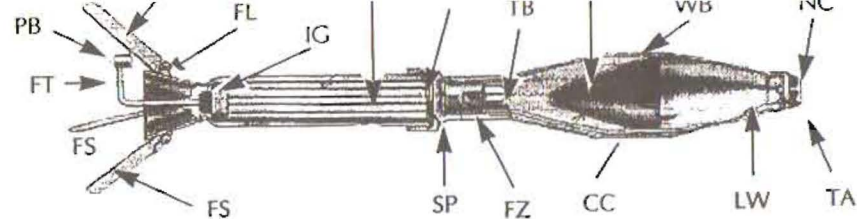

FIGURE 3: Cross section of 66mm LAW rocket

PB	Primer block	FZ	Fuze
FS	Spring-loaded fin	TB	Tetryl booster
FT	Flash tube	WB	Warhead body
IG	Igniter	LW	Lead wire (running from TA to FZ)
FL	Fin lugs	CC	Copper cone
SP	Stud plate	HE	High explosive
PG	Propellant grains	NC	Nose cap
CT	Closure threads	TA	Terminal assembly ("LUCKY")

the booster charge of tetryl and, via this, the main shaped charge. The copper cone is converted into a highly penetrating jet of plasma. The difference between the M72A1 and M72A2 is simply the improved armor penetration of the latter.

THE SIGHTS

The rear sight of M72A1 and later-series systems incorporates a spring-loaded aperture plate that compensates automatically for temperature variations. A rubber cover is fixed to the top of the sight. The front sight consists of a central, vertical range line indicating ranges from 50 to 350 meters in 25-meter increments. Range estimation is facilitated by two diverging stadia lines, which will bracket a 6-meter (20-foot)-long target at that range. The range-finding system assumes that the target is twice as long as it is high. Provision for aim-off (lead) on a moving target takes the form of crosses, which are

visible on the extreme left and right of the sight plate. These give the correct lead for a directly crossing target traveling at 24 kilometers per hour (km/h), or 15 mph.

THE TRAINING LAUNCHER

Introduced for the purposes of realistic instruction, the training launcher consists of a normal M72A1 tube containing a telescoping M190 subcaliber launcher assembly and the M73 35mm subcaliber rocket. The subcaliber insert is reusable. Sighting and firing procedures are the same as for the tactical weapon.

The M73 35mm rocket consists of a detonating warhead, rocket motor, motor closure, and igniter assembly. The warhead is made of rigid plastic and contains approximately 1.5 grams of M80 composition mixture. The front part of the motor closure contains a base detonating fuze and an M26 stab primer. When the rocket strikes a target an inertia-driven firing pin strikes the primer, thereby setting off the head charge. Although primarily a spotting charge producing noise, a flash, and smoke, this will penetrate approximately 3 millimeters of steel plate or 20 millimeters of soft wood.

The rocket motor casing itself is metal and contains three tubular grains of M7 propellant. Stabilization in flight is provided by six molded plastic fins.

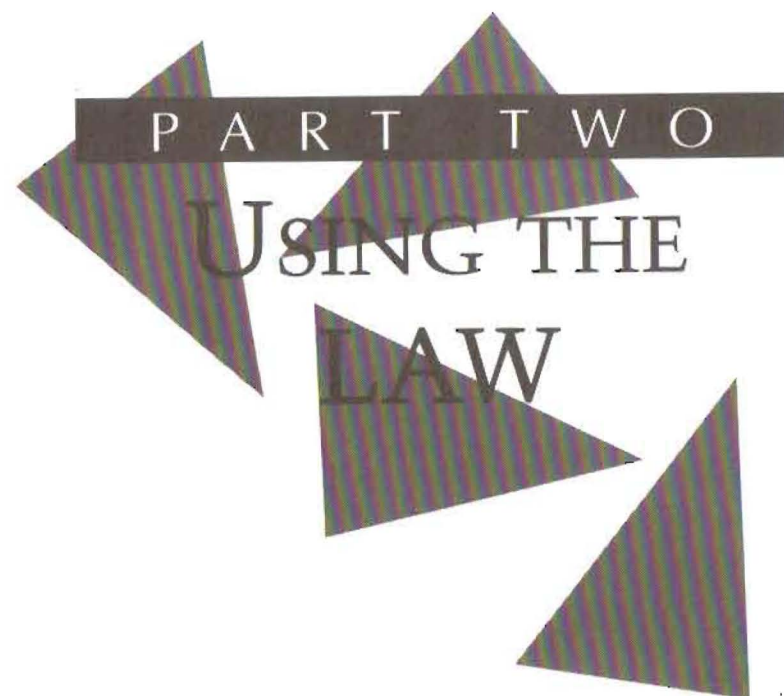

PART TWO USING THE LAW

The following section is a reprint of the U.S. Army LAW user manual. It contains full details of how to arm, aim, and fire the system, as well as the actions that should be taken in the event of a misfire. This information applies to tubes of American and European manufacture.

A BRIEF DESCRIPTION

II
SECTION
II

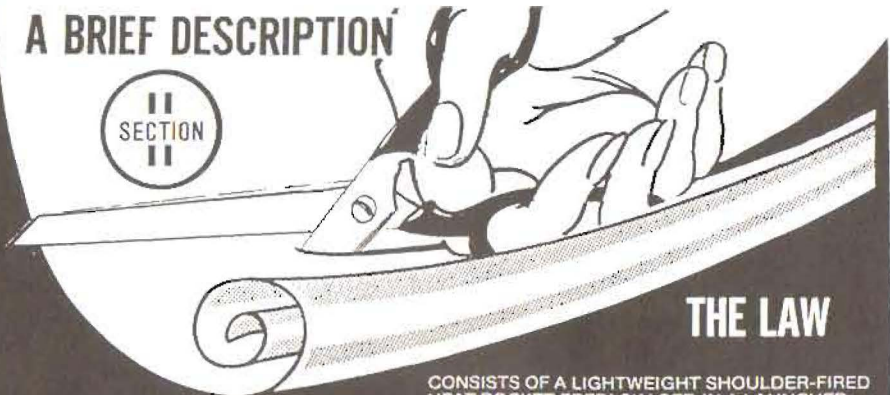

THE LAW

CONSISTS OF A LIGHTWEIGHT SHOULDER-FIRED HEAT ROCKET PREPACKAGED IN A LAUNCHER. END COVERS PROTECT ROCKET AGAINST DIRT AND MOISTURE. THE WEAPON IS CARRIED SLUNG OVER THE SHOULDER BY AN ATTACHED SLING ASSEMBLY.

THE PRACTICE LAUNCHER, M190, IS A MODIFIED M72A1 LAUNCHER CONVERTED TO FIRE A 35-MM M73 ROCKET. THE ROCKET WHICH CONTAINS A SPOTTING CHARGE, SIMULATES THE FIRING OF THE TACTICAL WEAPON.

WEAPON

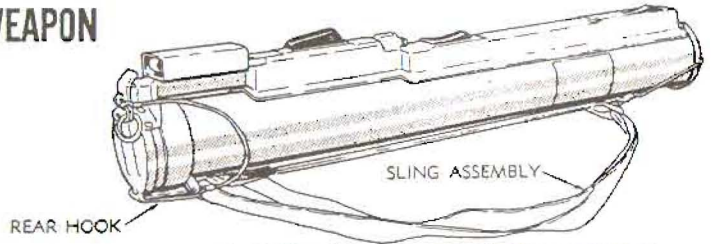

EXTERNAL VIEW AS ISSUED (NOT EXTENDED)

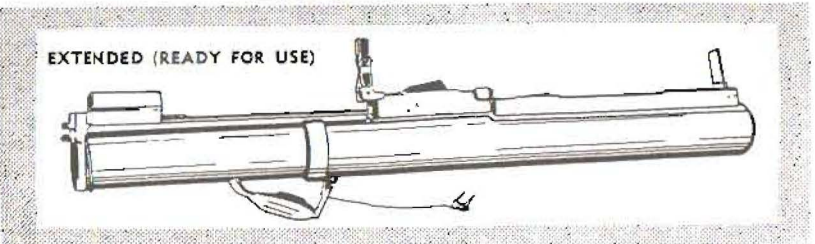

NOTE: EXTERNAL VIEW OF TACTICAL AND PRACTICE WEAPON ARE IDENTICAL

III
SECTION
III

DATA

WEAPON DATA

	Tactical		Practice
	M72A1	M72A2, M72A3	Launcher M190 w/Rocket M73
Weight	5.1-Lbs.	5.1-Lbs.	5.-Lbs.
Color Identification Launcher Firing Instruction Label	OD OD Background White Printing	OD OD Background White Printing	OD OD Background White Printing
Model, Lot No, Date Mfg Label	OD W/Yellow Printing	OD W/Yellow Printing	OD W/ Yellow Printing
Warhead	M72 (Heat)	M72A1 (Heat)	Spotting Charge
Complete Length (Closed) Nominal (Open) Nominal	24.7-In. 34.7-In.	24.7-In. 34.7-In.	25.3-In. 35.4-In.
Diameter	4.9-In.	4.9-In.	4.9-In.

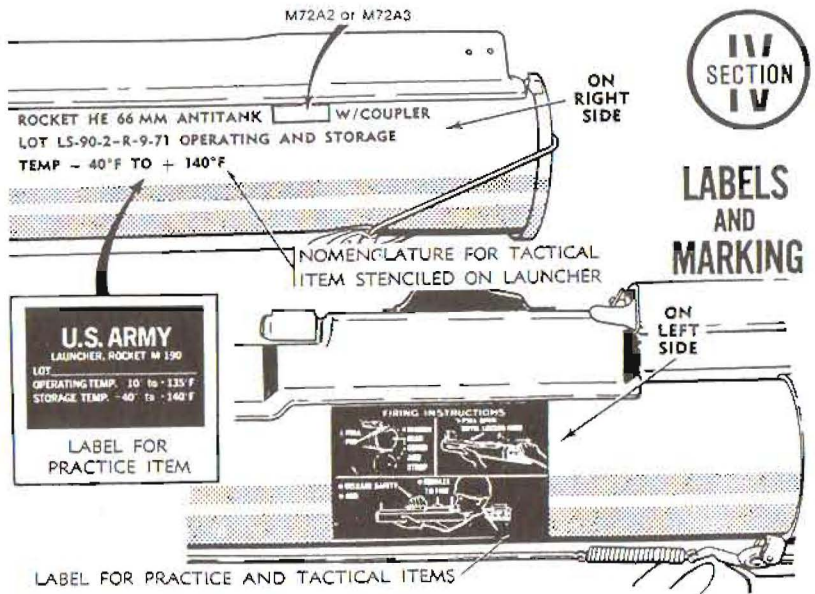

IV
SECTION
IV

LABELS AND MARKING

THIS PAGE INTENTIONALLY
LEFT BLANK

Following applies to tactical weapon only.



SERVICE UPON RECEIPT OF MATERIEL

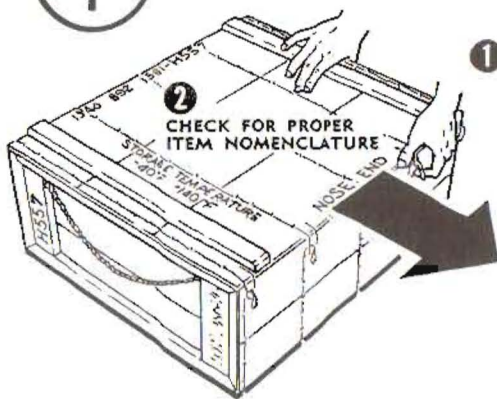

1 KEEP MARKING "NOSE END"
OF BOX FACING LEAST
HAZARDOUS AREA

3 STAND TO SIDE
OF "NOSE END"
MARKING.

4 REACH OVER
TOP OF BOX
AND UNFASTEN
WIRE HOOPS

DO NOT USE SHARP
INSTRUMENTS OR HOOKS
TO PRY UP BOX COVER
OR OPEN INNER PAK

CHAPTER 2 OPERATION

5 REMOVE FIBERBOARD
CONTAINER BY HANDLE

6 PULL FLAP
AT NOSE END
OF BARRIER BAG
AND OPEN TO EXPOSE
CONTAINER END

7 PULL PREPARED TEAR
STRIPS OFF CONTAINER
END AND REMOVE COVER

8 REMOVE
CUSHIONING
AND WEAPON

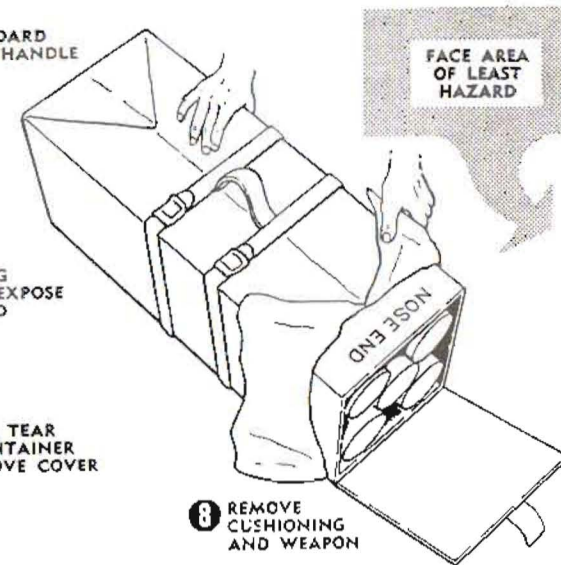

FOLLOWING APPLIES TO TACTICAL AND PRACTICE WEAPONS

CHECK EACH WEAPON SYSTEM FOR

CRACKED TUBE
DENTED PARTS
MISSING PARTS
LOOSE PARTS

FRAYED SLING
LOOSE OR BENT REAR HOOK
LOOSE OR DAMAGED SAFETY MECHANISMS
BLURRED OR INCORRECT NOMENCLATURE

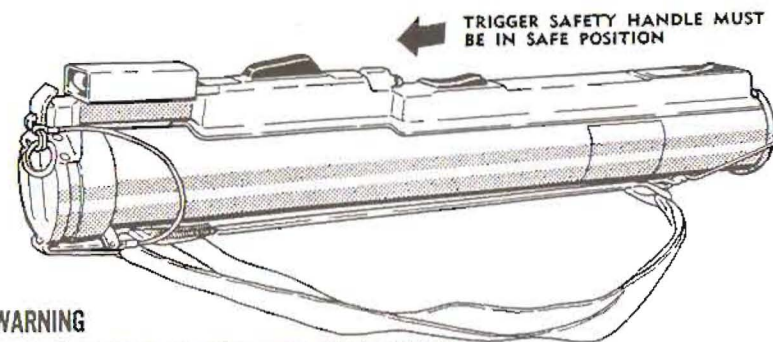

WARNING

DO NOT EXTEND LAUNCHER UNTIL READY FOR USE.

FOR TACTICAL WEAPONS ONLY.

IF TIME PERMITS

CHECK IGNITER FOR DAMAGE (BROKEN, CRACKED OR SPLIT) (SEE INSTRUCTIONS FOR REMOVING CARRYING SLING)

IF SO DAMAGED

TAPE DAMAGED IGNITERS TO PREVENT LOSS OF IGNITION MATERIAL. REPLACE SLING ASSEMBLY. CLOSE REAR COVER AND REPLACE PULL PIN.

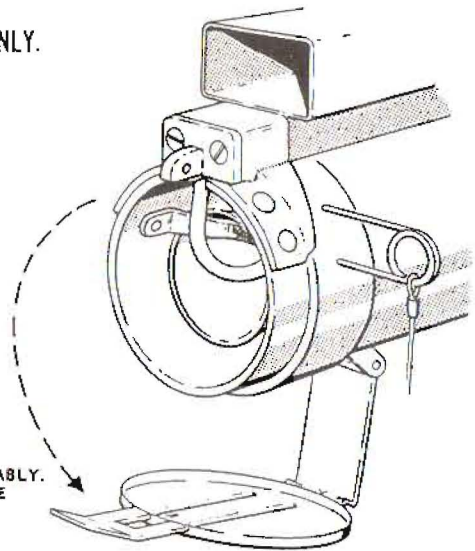

CARRYING POSITION

TO CARRY
SLING OVER SHOULDER

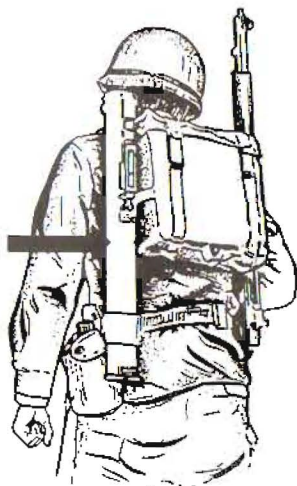

WARNING

DO NOT CARRY WEAPON IN EXTENDED POSITION.



BACK BLAST DANGER ZONES

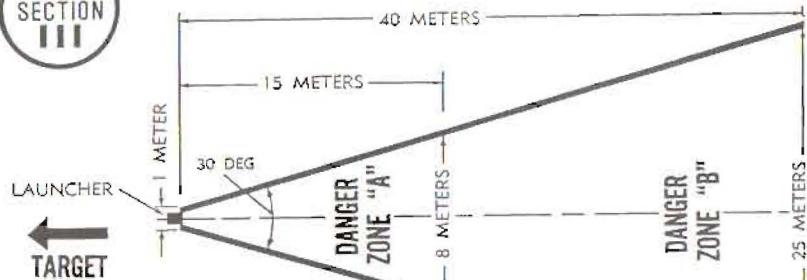

WARNING

DO NOT FIRE UNLESS . . .

1. Back blast area is clear of personnel and obstructions.
2. Body extremities are clear of Rocket exhaust end.

ZONE "A"
DANGER IN THIS AREA FROM BLAST, HEAT, AND PROJECTED MATERIALS.

ZONE "B"
DANGER IN THIS AREA FROM PROJECTED MATERIALS



PREPARATION FOR FIRING

All weapons



- 1 The Following Steps Are Performed At The Firing Point.

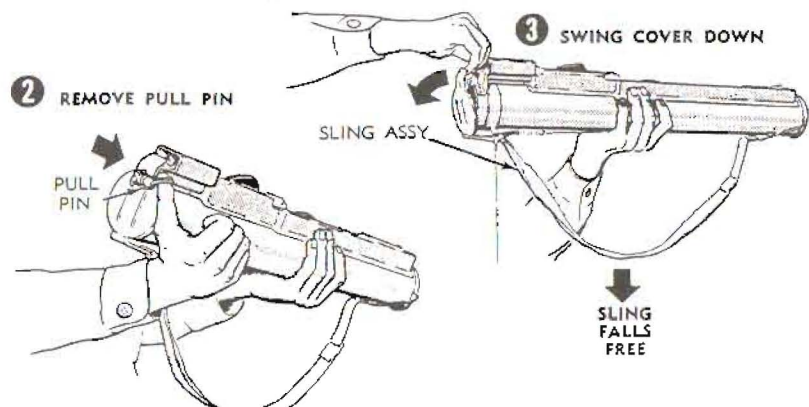

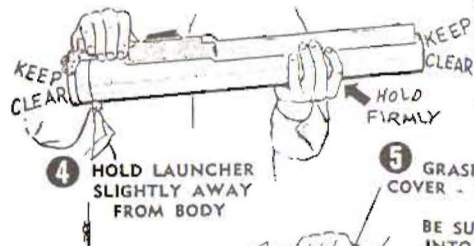

IF TWO ATTEMPTS TO LOCK LAUNCHER OPEN FAIL - CLOSE AND SET SYSTEM ASIDE FOR DISPOSAL BY AUTHORIZED AMMUNITION PERSONNEL (SEE SECTION X FOR CLOSING WEAPON)

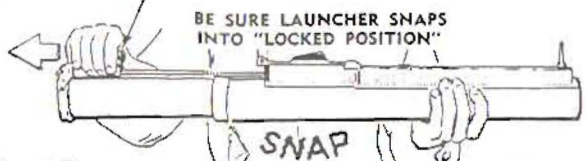

6 EXTEND BY PUSHING OUT WITH RIGHT HAND

WARNING EXTENDING THE WEAPON TOO SLOWLY CAN RESULT IN FAILURE TO COCK THE WEAPON.

KEEP LAUNCHER ON TARGET

FIRING POSITIONS

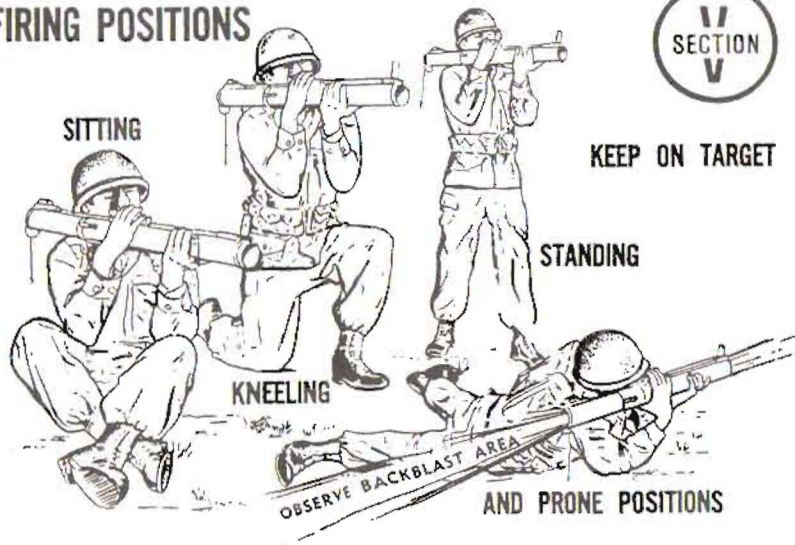

V SECTION V

VII SECTION VI

READY

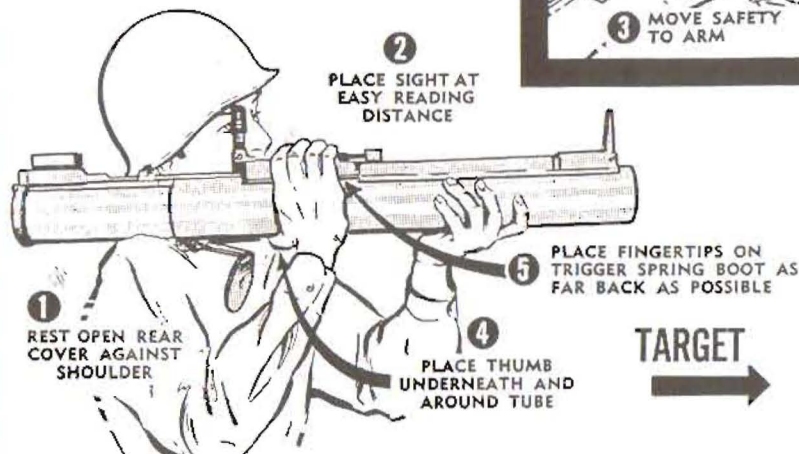

VIII SECTION VII

AIM

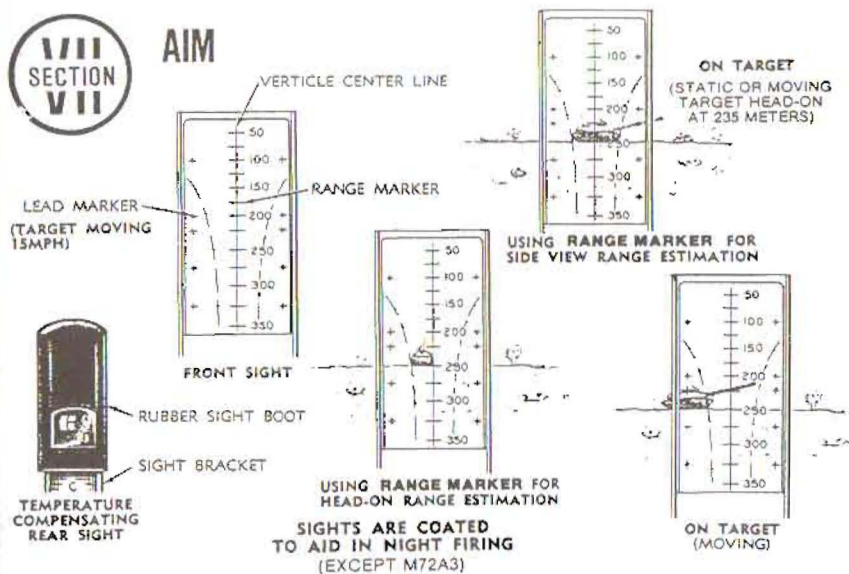

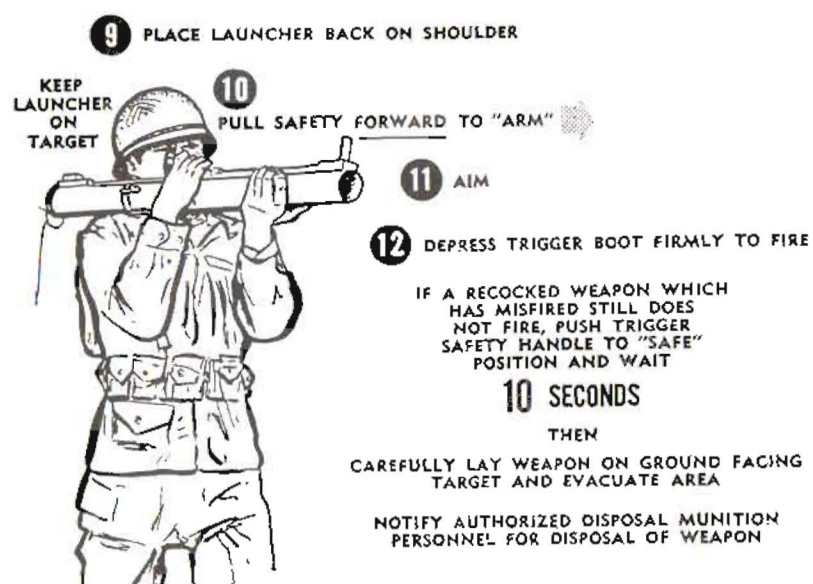
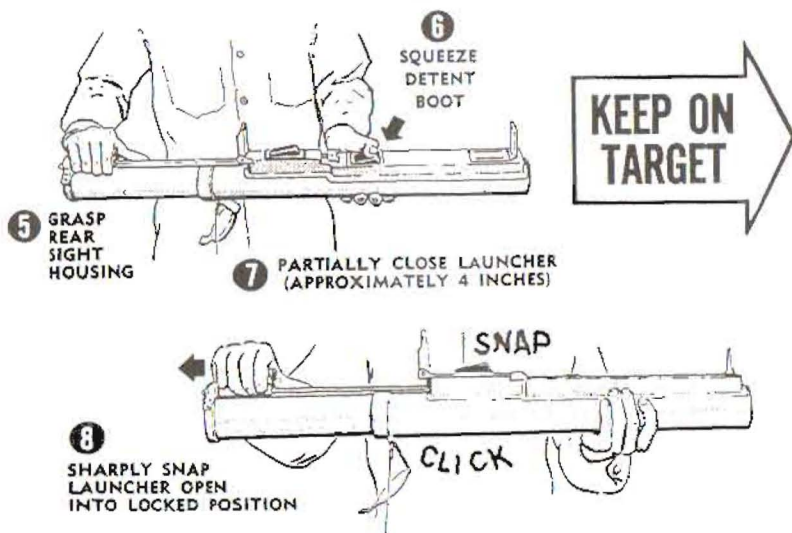
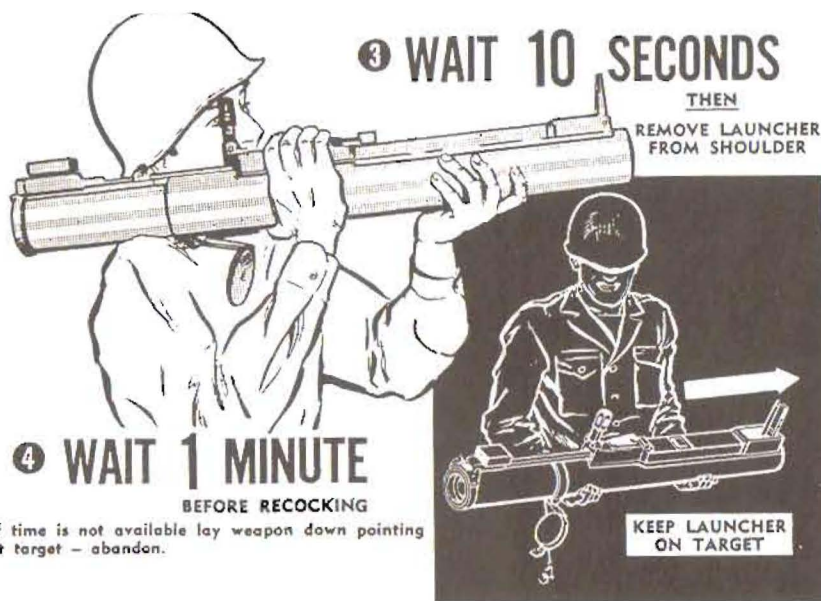

PREPARED FOR - BUT NOT FIRED

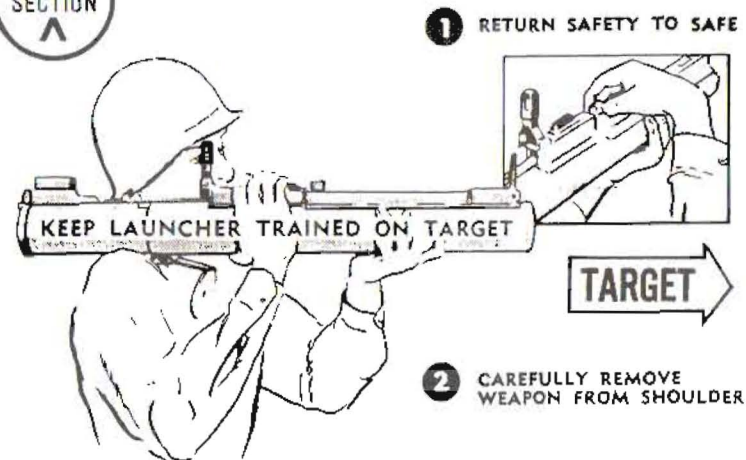

3 GRASP LAUNCHER BY REAR SIGHT HOUSING

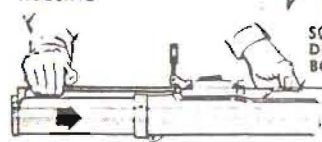

5 SLIDE INNER TUBE INTO OUTER TUBE APPROXIMATELY TWO INCHES



PERFORM ALL COMPRESSION ACTIONS SLOWLY TO AVOID INJURY TO FINGERS

KEEP ON TARGET

4

SQUEEZE DETENT BOOT

7 GRASP LAUNCHER NEAR FRONT SIGHT AND HOLD DOWN FRONT SIGHT



8 COMPRESS UNTIL EDGE OF INNER TUBE TOUCHES THUMB LIGHTLY

6

REMOVE THUMB FROM DETENT BOOT

9 FOLD DOWN REAR SIGHT AND GUIDE UNDER HOUSING

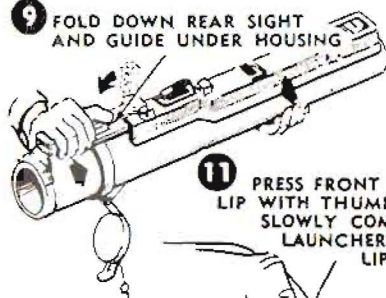

10 COMPRESS LAUNCHER UNTIL TRAVEL IS STOPPED BY LIP ON FRONT SIGHT

11 PRESS FRONT SIGHT LIP WITH THUMB AND SLOWLY COMPRESS LAUNCHER OVER LIP EDGE

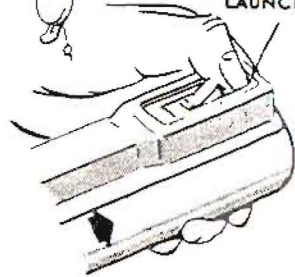

12 REMOVE THUMB FROM FRONT SIGHT AND GRASP HOUSING

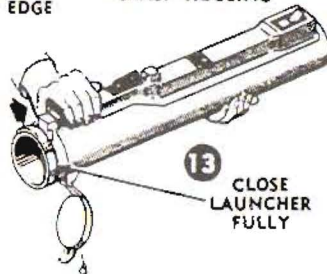

13 CLOSE LAUNCHER FULLY

14

REPLACE COVER PIN

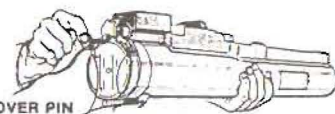

KEEP LAUNCHER POINTED DOWN RANGE

15

REPLACE BUFFER PLATE (M72A3 ONLY)

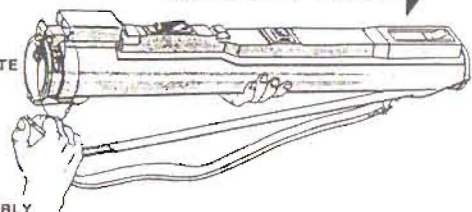

16

REPLACE SLING ASSEMBLY

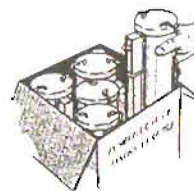

LAUNCHER AND PACKING SHOULD BE MARKED OR TAGGED TO INDICATE LAUNCHER HAS BEEN EXTENDED

WHEN POSSIBLE ONCE - EXTENDED LAUNCHER SHOULD BE RETURNED TO ORIGINAL PACKING

CHAPTER 3 MAINTENANCE

I SECTION I



OPERATOR MAINTENANCE

NORMAL CONDITIONS
KEEP LAW CLEAN AND DRY

UNUSUAL CONDITIONS
PROTECT LAW FROM MOISTURE,
SNOW, SLEET, CLEAN AS REQUIRED



PART THREE

REARMING
THE LAW

DISASSEMBLY

All disassembly and reconstruction procedures outlined here are to be performed with the LAW tube in the closed state with the safety catch on "safe." Check that your LAW is empty! A good rule of thumb here is that if you can see through the tube, it is, indeed, empty. This assumes, however, that you have removed the end caps.

Undo the two screws (S) visible at the rear of the tube,

as shown in Figure 4. This will allow the primer housing block cover (BC) to be lifted off. If the housing is secured with rivets rather than screws, grind or cut the rivet heads away and drift out the remaining pins. Obtain self-tapping screws of a suitable length and diameter for subsequent replacement of the housing. Better still, use wing nut-type fasteners, as this makes for very rapid repeated rearming.

FIGURE 4: Primer block housing cover

S Screws
BC Block cover

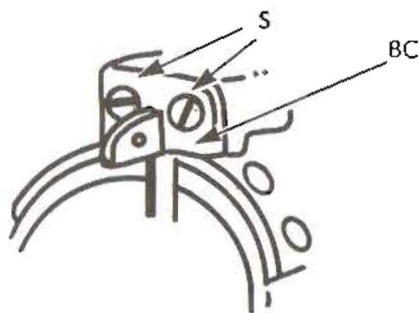
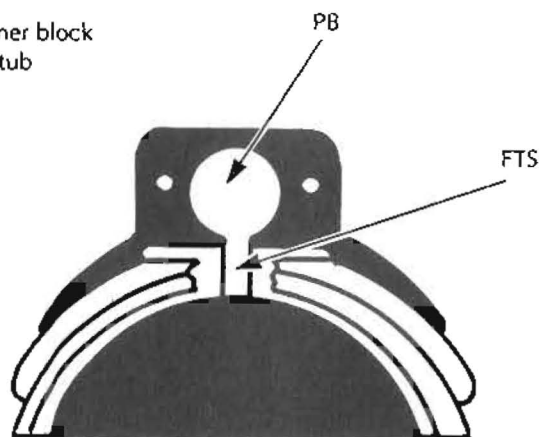

FIGURE 5: Primer block and flash tube stub



Scrape and pull away any silicone waterproofing material that is present. You should now be looking at the primer block assembly (PB) and (if you're lucky) the stublike remains of the plastic flash tube (FTS).

Pry out the primer block with a levering action using the longer of the LAW's safety-pin pair, the pointed bit of a Swiss Army pen knife bottle-opener blade, or any other expedient tool that can be inserted beneath the flash tube stub. Do not damage the stub unnecessarily.

Now remove the existing (used) primer. Usually, the LAW firing pin will have seriously pierced the face of the primer. This being the case simply enlarge the hole carefully with a knife blade until a medium-sized Phillips screwdriver can be inserted. (The crosshead bit catches the damaged brass better than a flathead does.) Twist the screwdriver to loosen the primer in its pocket, then lever or pull out the primer with a pair of pliers.

Check now that the vent hole at the bottom of the

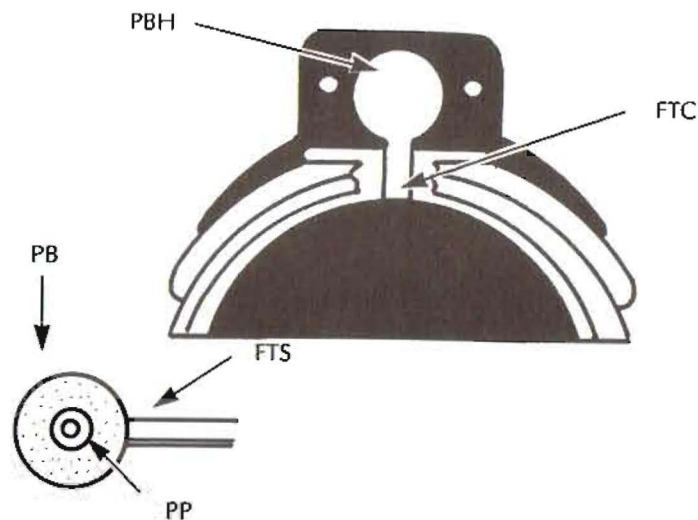

FIGURE 6: primer block (stub attached) removed from housing

PBH Primer block housing
PP Primer pocket
PB Primer block
FTS Flash tube stub
FTC Flash tube channel

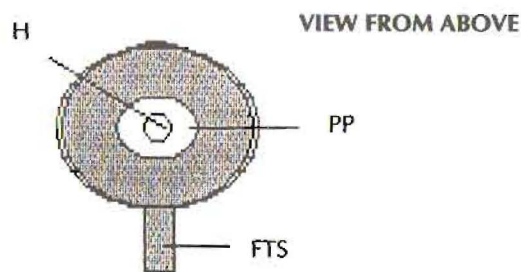
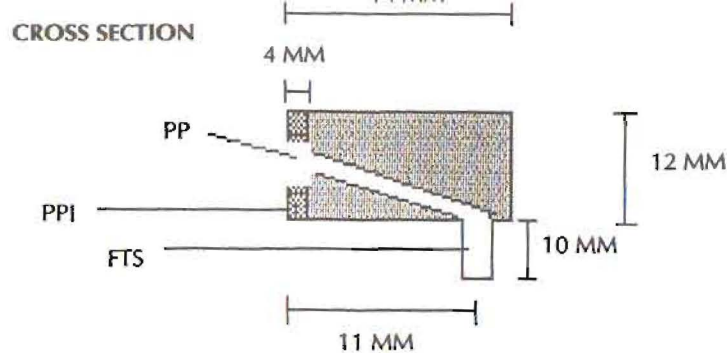

FIGURE 7: Schematic diagram of primer block

PPI Primer pocket insert FTS Flash tube stub
 PP Primer pocket H Hole

primer pocket is not blocked and that the small stub of flash tube remaining on the primer block is clear also. Trim the edges of the stub so that there are no split or flared ends. If the stub section is too short or even missing (having been burnt away during the original firing), then clean up the area around the hole left in the block and attach a replacement stub made from hard plastic or metal piping.

Drill out the hole in the block slightly, if required,

to facilitate accurate fitting of the replacement stub. Secure with epoxy adhesive applied to the outer rim of the stub and immediate block area only. Don't get any inside the tube.

If the primer block is missing from your LAW, a replacement can be made using the above specifications. Use nylon dowel or even a cut-down, fired, 7.62-millimeter "Boxer" primered rifle case. In the case of the latter the open end of the case can be sealed with a friction-fit brass disk soldered in place for security. Use aluminum solder, as this joins brass more easily than standard electrical solder, although a higher bit temperature is required. Remove the primer before commencing any modifications.

A flash channel insert (for use with the cut-down case) can be made from stiff plastic tube of approximately 2- to 2.5-millimeter internal diameter and 4-millimeter external diameter. This worked well in tests. Metal piping could be employed just as easily. The insert is cut as shown in Figure 8 and installed and secured initially with a small amount of adhesive at each end. When this has dried, the remainder of the space inside the case can be filled with epoxy prior to sealing the end.

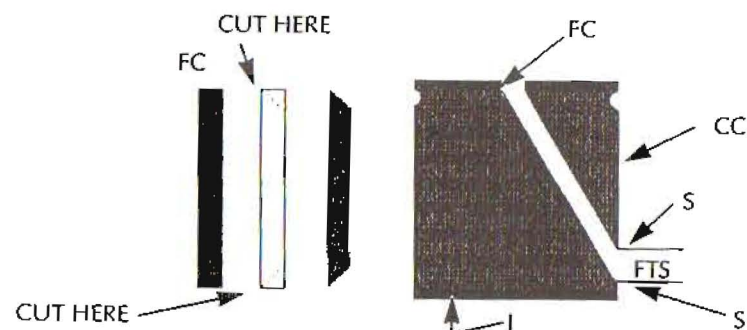

FIGURE 8: 7.62mm casing primer block

FC Flash channel insert FTS Flash tube stub
 CC Cut-down case I Insert
 S Solder

The hole for the flash tube stub should be drilled to a diameter that allows the tube to be inserted a little ways into the body of the block. It can be secured with epoxy adhesive (assuming a nylon block and plastic tube) or with solder (if using a metal block and metal tube). If using epoxy, thread a pipe cleaner (via the primer pocket hole) through the flash tube stub to clear it of adhesive before the material dries.

Another alternative is to simply fill the cut-down case with epoxy adhesive and, when it has set, drill out the required channel and flash tube opening with a 2-millimeter-diameter bit. In fact, there is any number of ways to achieve the desired effect and, if the examples given here start you thinking and you come up with an improved method, so much the better.

At this stage the correct operation of the LAW safety catch and firing mechanism should be tested. Do this by installing a toy cap (of the type used in children's 8- or 12-shot revolvers) in place of the primer. This type of cap is plastic and is usually supplied in "circles" of 8 or 12, which are packed 6 circles to a box. Typical brand names are Super Disc and Ammo King. The Super Disc type is made by Edison Giocattoli, 50019, Sesto Fiorentino, Italy, and is imported by Toys 'R' Us.

Those used in tests were about 5 millimeters in diameter (with a slightly wider top flange) and 5 millimeters deep and were an excellent friction fit in the primer pocket. Note that they will stick up above the primer housing face slightly (about 1 to 2 millimeters) when installed.

This type of plastic cap will be used later in the completed weapon. It is more than likely that there are proper commercial primers or metal blanks of a suitable size and power that can be used instead. If you are familiar enough with the field to make an intelligent selection, you might want to experiment. The only cautionary note I would sound is that too powerful a primer may well blow the igniter assembly (not to men-

tion the primer block housing and rear cover) apart rather than initiate the rocket propellant. (Time constraints and the need to dodge a BATF search team looking for the LAWs we stole to experiment with during the writing of this booklet prevented us from testing all possible alternatives.) Anyway, toy caps can, in many parts of the world, be obtained with greater ease and less suspicion than primers.

So push the cap home as far as it will go, but don't bother to force it. It will be compressed somewhat when the cover is refitted. The design of the LAW firing pin is such that there is no risk of the cap being forced against it (and therefore causing it to fire) during this procedure.

Now replace the primer block in the housing and attach the cover plate. Tighten the cover screws alternately a couple of turns at a time until the plate is secure. Having checked that no one is staring down the rear of the tube, extend the tube, pull the safety catch out to arm the weapon, and fire. Isn't that little echoey "bing" satisfying?

If the weapon doesn't fire, recock (close and extend) and try again. If nothing happens this time, close the tube down, check that the safety is on "safe," and disassemble the primer block housing. If the cap base is pierced or severely indented the firing system is okay. Try again with a fresh cap.

If all was well, run through the procedure again a couple of times. Get used to performing the correct misfire drills. If you don't get any misfires, pretend. Overcome any tendency to look down the tube and/or point the back of it at your own body when opening and closing the weapon, and practice not closing your eyes when you depress the firing button! Confirm that the weapon will not fire when the safety handle is pushed in.

The next stage is to attach a new length of flash tube to the stub on the primer block and perform a flash tube test.

A replacement flash tube can be made from semirigid

plastic tubing, 5-millimeter external diameter, 4-millimeter internal diameter. The wall diameter will therefore be 1 millimeter. These dimensions facilitate easy attachment to the stub. The type of tube used is not critical, the primary requirement being that it doesn't kink severely when gently bent through a curve.

In tests we successfully used a length of outer insulation pulled from coaxial cable of the type commonly used for CB and ham radio hookups. This has an internal diameter of around 4 millimeters and an external diameter of around 5 millimeters.

For this test use a 63.5-millimeter length of tube. The procedure is as follows:

1. Place a safety match head in one end of the tube and tape it up.
2. Install a cap in the primer block.
3. Now force the open end of the new tube over the stub on the primer block and push it home until it is flush with the block body.
4. Refit the primer block (cap side inward!) and fasten the cover plate. When you are fitting the primer block, the area of flash tube that covers the flash tube stub will make for a tight friction fit within the flash tube channel. Subsequently locking it down by the cover plate ensures that the tubing will not simply blow off the stub when the cap fires. Bend the tube forward and upward so that it is roughly central in the launcher, and secure it in this position with tape or any expedient support. This replicates the angle through which the flash from the cap will have to travel to fire the igniter.

Test-fire the weapon following all previously men-

tioned safety requirements. The match head should ignite instantaneously and will (depending on the type and amount of tape you used to seal the end of the flash tube) probably be propelled out of the front of the launcher.

If the match lights, your choice of tubing and cap is okay and the system will initiate the improvised igniter described later. If the match doesn't light, check for a split in the flash tube where it exits the primer block housing. The flash tube will split here if the tube was kinked badly during firing. Try a stiffer type of tubing or a different cap. We will now leave this aspect of the firing system for a while and move on to the rocket itself.

THE ROCKET

This section gives details on constructing a replacement rocket for the LAW. The rocket is a nominal 66mm round as per the original, albeit of lighter construction and with fixed fins.

Basic Principles

Rockets (and jets, for that matter) fly in accordance with Newton's third law (how appropriate) of motion, which states that for every action there is an equal and opposite reaction. Here that means that a force equal to that produced by gases (from the burning propellant) escaping through the exhaust nozzle is exerted in the opposite direction, thereby driving the rocket forward. The rocket's movement is not dependent on a buildup of gas pressure behind it.

The power source used here is based on the D12-O or D12-P type of flying model rocket engine, available from most toy and model shops. It will be used to power a rocket consisting of the following parts:

1. Nose cone (NC): One plastic flying model rocket kit, nose cone type PNC-80K, modified as

described, or improvised cone of similar dimensions (see fig. 9).

2. Nose insert (NI): Plastic flying model rocket kit, type PNC-80BB or wood, plastic, or light metal improvisation (some plastic caps from aerosol sprays are suitable, as are various plastic soft drink bottles if cut down to the correct diameter).
3. Body tube (BT): Hard plastic or fiberglass tubing or flying model rocket body tubing, 41.6-millimeter outside diameter, 40.5-millimeter internal diameter, 273 millimeters long.
4. Engine mount assembly (EM): flying model rocket type EM05055/60 (or improvise from illustration below).
5. Stabilizing fins (SF): Six fins, metal, plastic or wood, 95.3 millimeters long, 1.6 to 2.4 millimeters thick (depending on material used), 11 millimeters high, shaped as per Figures 16 and 17.

Nose Cone Assembly

Cut off the lower (insert) part of the longer of the two plastic nose cones as indicated in Figure 9, taking care not to damage the remainder of the cone. This will leave you with a nose cone of the dimensions shown in Figure 10. Now pack the inside of one end of the body tube with epoxy adhesive to a depth of about 70 millimeters and apply epoxy to the front of the cut-down nose cone to a similar depth. Insert the nose cone into the body tube as far as it will go and wipe away any excess adhesive.

Using a spirit level and blocks, check and adjust the cone until it is perfectly centered. Secure the joint with plastic electrical tape and set the assembly aside to dry.

When the tube and cone assembly has dried, the nose insert can be installed into the open front of the plastic cone. For "dry" firings the friction fit will suffice. If explosive components are to be installed, the joint should be sealed with a thin layer of epoxy.

ENGINE MOUNT

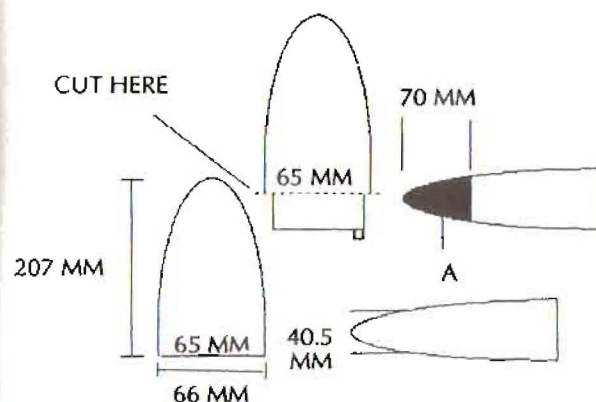

FIGURE 9:
Nose cone

A Adhesive

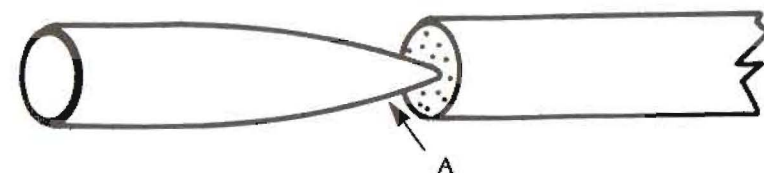

FIGURE 10: Inserting nose cone into body tube

A Adhesive

The engine mount can now be installed. This is a flying model rocket kit type EM-5055/60, or it may be improvised as per Figure 14. The mount should be

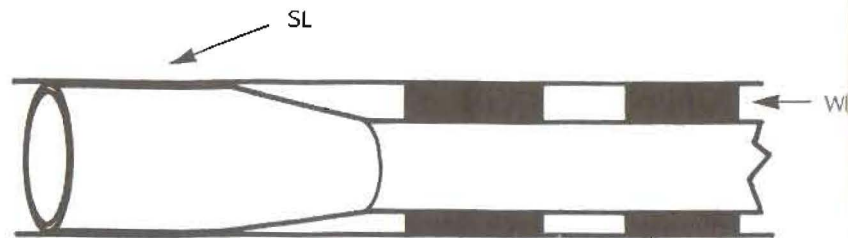

FIGURE 11: Aligning the nose cone

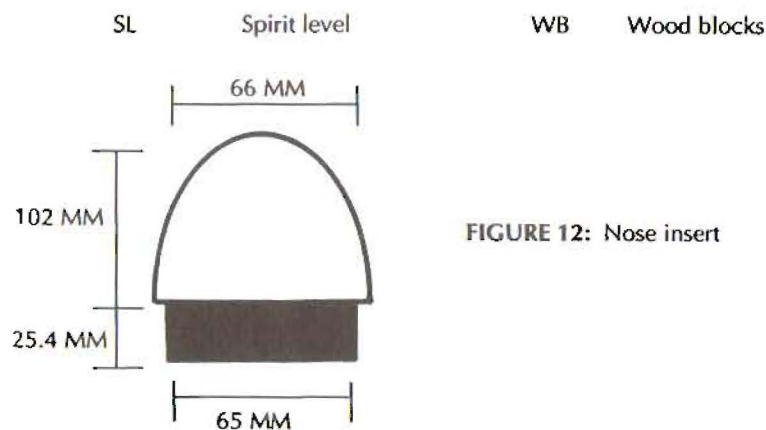

FIGURE 12: Nose insert



FIGURE 13: Installing the nose insert

installed in the body tube so that the end of the metal engine holder on the mount protrudes about a quarter inch (6.4 mm) beyond the end of the body tube. The other end of the sprung metal holder actually penetrates the engine tube, where it acts as an engine stop. The holder is held in place by the plastic retainer (PR). This is a length of plastic or rubber tubing forming a tight friction fit over the engine holder and tube.

When it is not necessary to recover and reuse the rocket, an alternative engine-mounting technique can be used. Simply use a balsa wood cylinder with an external diameter that makes for a friction fit inside the body tube, the rear end of which is drilled centrally to accommodate the engine. This drilled housing should be shorter than the engine length by about a quarter inch. Both balsa insert and engine are secured with epoxy.

ENGINES

Propulsion is provided by a D12-O- or D11-P-type flying model rocket engine, modified by carefully drilling through the propellant of the engine centrally from the nozzle opening to the other end with a 1/8-inch (31.8 mm)-diameter drill bit and then (in the case of the D12-O engine) plugging the open end of the engine case with epoxy. Save the propellant powder produced during the drilling; it will be used later.

STABILIZING FINS

The fins are attached one at a time in the positions indicated in Figures 16 and 17 with epoxy adhesive (in the case of fiberglass or heavy card body parts) or, if using metal parts, a spot weld, braze, or solder in the position shown.

Care should be taken to ensure that the fins are perfectly straight. Once attached they can be strengthened by running a thin bead of epoxy along each side of the

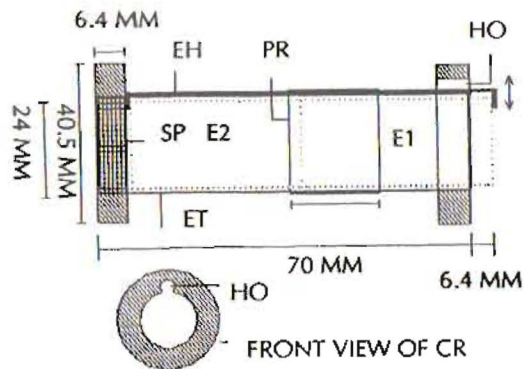

FIGURE 14: Diagram of engine mount

- ET Engine tube: stiff card, 70 mm long; internal diameter, 24 mm; external diameter, 25.4 mm
- CR Centralizing rings: two rings made of stiff card or plastic, 6.35 mm deep, internal diameter allowing friction fit on ET, external diameter allowing friction fit in 40.5 mm body tube
- EH Engine holder: length of spring steel, 3 mm wide, .5 mm thick, 70 mm long with the last 63.5 mm of each end bent at a 90-degree angle.
- SP Stop piece: wooden or metal disk, 6.35 mm thick, diameter facilitating friction fit in ET
- PR Plastic retainer: plastic tubing, 25.4 mm long, diameter allowing a friction over EH and ET
- HO Hole: located as shown to facilitate upward movement of EH for engine installation
- E Position of engine

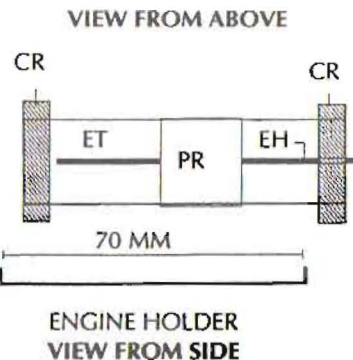
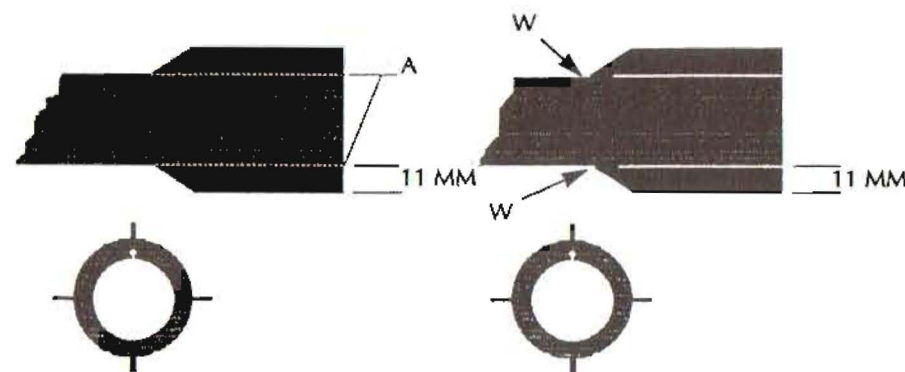

FIGURE 15: Engine holder detail

attachment point. "Fin alignment guides" are available commercially from flying model rocket suppliers.

Note that in the case of metal body parts the fins are attached with only a single spot weld or braze. This allows for subsequent minor straightening.

Once the fins are attached, check to be sure that the rocket can actually be inserted into the tube without hang-ups. Load the rocket, fins first, into the front of the closed tube. As it is the rearmost (inner) tube that has the smaller diameter, it is this one in which you are checking for fin clearance.



FIGURES 16 AND 17: Fin dimensions and positioning

A Epoxy adhesive

W Spot weld

If the fins catch on the innermost tube, remove the rocket and measure the height of each fin. If any are slightly higher than the others, sand or file their top edges very carefully to bring all the fins to the same height and then continue until the overall height of the fins (diameter of the fin assembly) is such that the rocket can be inserted all the way into the tube without difficulty.

THE IGNITER

The heart of the improvised igniter described here is the nozzle from a tube of silicone sealer (bath or window sealer) or some similar improvisation. It is via this and the flash tube that the flash from the cap or primer will be communicated to the engine propellant.

Step one is to cut the nozzle in half and then cut off the tip at a point from the end that will give an opening of about 2 millimeters. Sand or trim the outside of the nozzle end, as required, to give an external diameter that provides the nozzle tip with a friction fit in the engine nozzle to a depth of about 10 millimeters.

A nozzle housing can now be prepared from a used D-series engine, per the diagram on the facing page (fig. 19). The holder is simply the nozzle end of a D-series engine. The engine nozzle hole is widened from the inside to provide a friction fit for the plastic nozzle in such a manner that with the plastic nozzle inserted from the inside of the clay nozzle, the last 10 millimeters or so of it protrudes beyond the card rim, as shown in Figure 19. The plastic nozzle is then secured and the clay nozzle reinforced with epoxy adhesive.

Now attach the nozzle assembly to the engine pack with masking tape. Pierce the tape at the holder notch spot and install the engine/igniter assembly in the rocket, orienting the assembly correctly so that the engine holder fits in the notch properly.

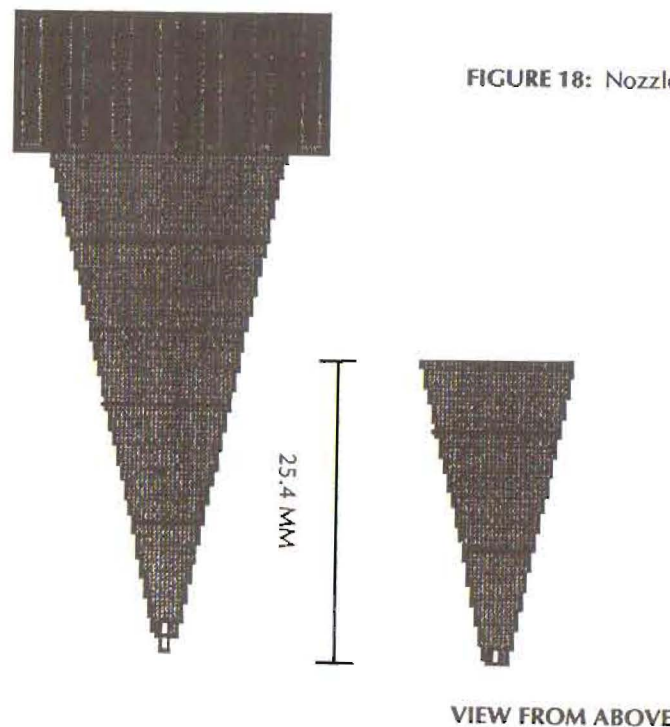
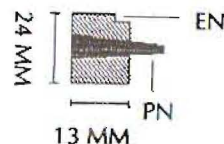
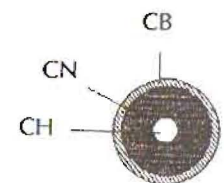

FIGURE 18: Nozzle

FIGURE 19: Nozzle housing

- EN Engine notch (4 x 4 x 4 mm notch to accommodate end of engine holder)
- CN Clay nozzle
- CB Card body
- CH Central hole
- PN Plastic nozzle



CROSS SECTION

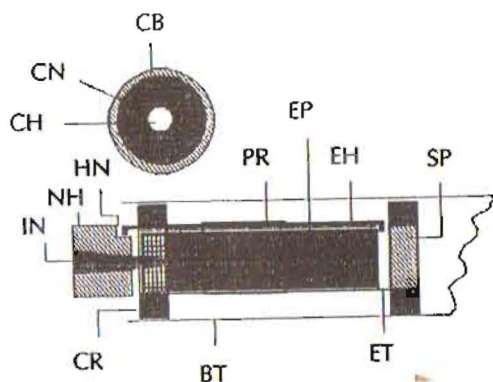

FIGURE 20: Igniter in cross section

CB	Card body (on cut-off engine nozzle)	CR	Centering rings
CN	Clay nozzle	BT	Body tube (rocket body)
CH	Central hole	PR	Plastic retainer
IN	Improvised nozzle	EP	Engine
NH	Nozzle holder	EH	Engine holder
HN	Holder notch (engine notch)	SP	Stop piece
HN		ET	Engine tube

Install the rocket in the tube (fin end first, from the front of the closed tube) so that the open end of the improvised nozzle is more or less flush with the back of the tube.

Next cut a 63.5-millimeter piece of improvised flash tube, push one end over the flash tube stub on the primer block, and install the primer block in its housing. Now trim the free end of the tube to a length (typically about 57 millimeters) that facilitates its insertion (fully, but without undue force) into the improvised igniter nozzle with as shallow a curve as possible (the idea being that there are no sharp kinks in the flash tube).

Having determined the correct length of flash tube required (which will vary slightly depending on exactly what type of material you have used), remove the rocket

and take out the engine/nozzle assembly. Remove the primer block and flash tube also but do not disassemble.

Now pour the propellant powder saved from the engine-drilling process into the nozzle, tapping the nozzle to encourage some of the powder to fall into the engine pack. Add powder until the nozzle itself is almost filled. Press the end of the tube down firmly into the center of the powder, turning it slightly as required to obtain a friction fit. Secure the tube with epoxy adhesive at the top of the nozzle as shown.

An alternative igniter nozzle can be improvised from two of the plastic igniter holders which are supplied with the engines. These are drilled centrally and secured back-to-back with Superglue or epoxy adhesive (or they can be secured with epoxy adhesive first and then drilled after drying). One end is inserted into the engine nozzle; the other has the lower end of the flash tube pushed over it.

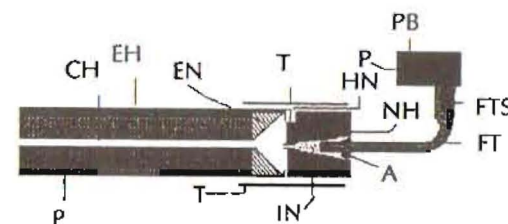

FIGURE 21: The completed igniter assembly

CH	Central hole	NH	Nozzle holder
EH	Engine holder (engine tube and centralizing rings not shown)	HN	Holder notch (to accommodate end of engine holder)
EN	Engine nozzle	FT	Flash tube
IN	Nozzle (containing propellant powder)	FTS	Flash tube stub
A	Adhesive	PB	Primer block
		P	Primer (cap)
		T	Tape

TRANSIT SAFETY

All that remains to be done now is to attach a simple improvised transit safety (round lock). There are several alternatives possible here, but a simple and effective technique is to wrap stiff wire around the nozzle holder a couple of times and secure it with epoxy. The wire is then bent up and out of the transit safety hole during end-cap replacement (looping the free end of the wire to take the safety pin).

FINAL REARMING

Final rearming involves installing the engine/igniter/flash tube assembly in the rocket (ensuring that the engine holder is retaining the engine correctly) and then loading the rocket into the launcher, fin first, from the front of launcher. If an improvised explosive round is loaded, this procedure should be undertaken with the launcher on the ground.

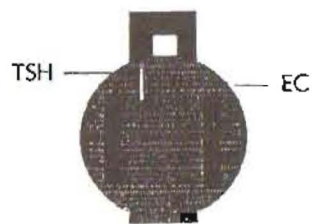
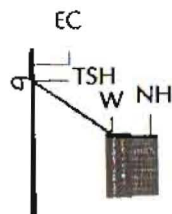

FIGURE 22: View of end cap showing position of transit safety hole

FIGURE 23: Wire transit safety attached to igniter nozzle holder

EC End cap
TSH Transit safety hole
W Wire
NH Nozzle holder



Lastly, a fresh cap is installed in the primer block and the primer block and its housing cover fitted.

TEST-FIRING

Although the device described here has been fired many times without problem, it is not beyond the realm of possibility that you have screwed yours up or that Murphy is about, so always make a test-fire wearing goggles, gloves, and a substantial jacket. This latter requirement sounds odd, but if you have failed to follow the instructions carefully and end up with a round that hangs up in the tube, the launcher will get very hot.

Make sure the area to the front and rear of the tube is clear. Remember that the system fires from an open breech, so the risk of the tube actually exploding due to a buildup of pressure is negligible.

Check the tube thoroughly for damage after this test-fire and all subsequent firings, and note that the rocket engine(s) will often leave a deposit in the tube that, unless cleaned away, will interfere with the subsequent insertion of another rocket.

There is some backblast when the rockets used here are fired as described. It is minimal, however, and goggles will provide adequate protection against smoke being blown into the eyes. If you intend to experiment with alternate designs, propellant types, or engine configurations, an improvised perspex blast shield should be fitted around the front of the LAW tube until the ABOL qualities of the experimental system are determined.

DISCARDING SABOT SUBCALIBER SYSTEM

Opting for a subcaliber rocket and a simple discarding sabot assembly provides an even more rapid route to rearming your LAW. Several suitable rocket

kits are available, and the only modification they require is a reduction in fin diameter to allow for a sliding fit within the rear of the LAW tube. The forward launch lug should be attached to such rockets, as per the kit instructions, but at least 25.4 millimeters from the front of the body tube.

The discarding sabot can be made from a cylindrical piece of balsawood, 25.4 millimeters in length and with an external diameter that allows for a sliding fit within the tube. The cylinder is bored out centrally to a diameter that provides a tight friction fit for the rocket body and then cut vertically into two halves. A short (3.2-millimeter) pin is driven into the center of each resulting face on one of the halves only. The other balsa half is then aligned correctly and pressed onto them. Finally, the resulting holes in the second balsa half are enlarged slightly to ensure that the pins move freely in them.

During loading the two halves are positioned around the rocket, just in front of the launch lug, thus forming a "collar" of the correct external diameter. When, upon firing, this part of the rocket exits the tube, the assembly will simply fall away.

LAUNCH ROD AND INSERT SYSTEM

Here a soft wood insert 65 millimeters in diameter and 9.5 millimeters thick is prepared by drilling out a hole 25.4 millimeters in diameter from its center and cutting a slot 12.7 millimeters deep and 6.4 millimeters wide from the center hole to any point on the outer rim. The rocket to be fired is now placed centrally over the center hole and oriented so that the front launch lug on the rocket is at least 6.4 millimeters to the left or right of the slot. Ink the end of the long-type Estes launch rod (or some sturdier improvisation of similar dimensions) and carefully place it through the launch lug until it contacts the insert. Drill the point thus marked by the ink to a

diameter that provides a tight friction fit for the end of the launch rod. Putting a drop of Superglue in the hole prior to fitting the rod will keep it secure. Open the LAW tube and position the insert in the rear of it. Mark the front of the launch rod where it exits the front of the tube. Remove this excess length to a point more or less flush with the front of the tube.

To use the system, install an engine and igniter assembly in the rocket as previously described, and then load the rocket into the tube and fit the primer block, and so on. Finally, feed the launch rod into the back of the LAW and through the launch lug and, having oriented the slot so that it covers the flash tube, press the insert as far into the back of the tube as it will go without using undue force. Check the front of the rocket for a more-or-less central position in the tube, and adjust as required by applying more pressure to the appropriate side of the insert.

Many of the smaller rocket kits are designed to use "C"-type engines. Greater ranges and/or payloads can be achieved, however, by not fitting the supplied engine-mount assembly to such rockets and instead installing a "D"-type engine directly into the rocket body tail section. This can be achieved by removing enough of the outer part of the card engine body to provide for a tight friction fit. In tests the Alpha III kit was successfully modified in this manner and used with the discarding sabot system described previously.



APPENDIX

WARHEAD

This section is included as an appendix, as neither the author nor the publisher really wants you to run around firing off live warheads. You're probably going to get into enough shit for firing the nonexplosive rounds anyway. The following illustrations show various ways in which an explosive warhead might be detonated upon impact. The designs are useful for incorporation into various other types of missile systems that you shouldn't be messing with either! Don't experiment

with them in conjunction with explosive materials unless you have a solid grasp of the field and the applicable industry-standard safety procedures.

MECHANICAL

A copper shear wire (S) passes through the housing (H) and body of the striker (ST). On impact, the pressure plate (PP) is forced into the housing, shearing the wire and allowing the striker pin (P) to hit the percussion cap (PC).

The striker pin is held clear of the percussion cap by a creep spring (S). On impact, pressure on the pressure

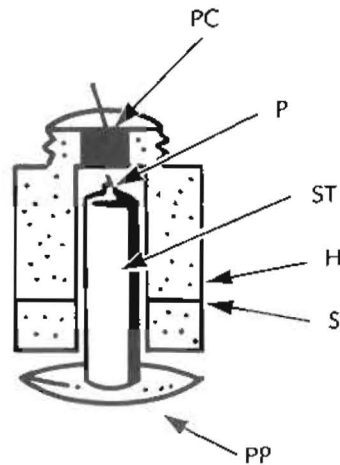

FIGURE 24: Shear pin

FIGURE 25: Creep spring—pressure

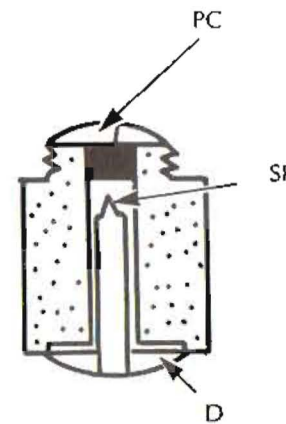
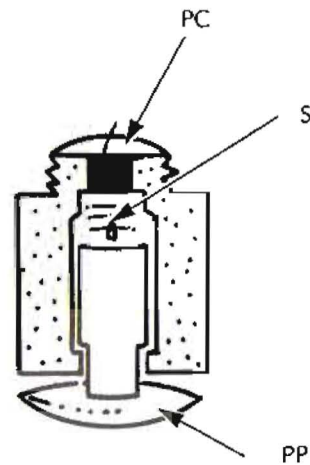

FIGURE 26: Diaphragm

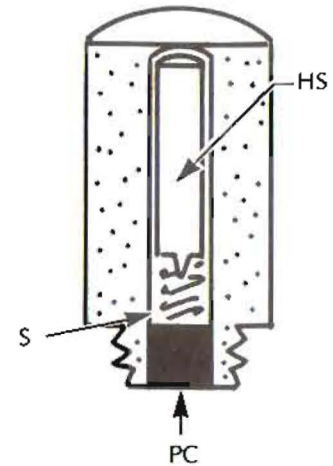

FIGURE 27: Creep spring—inertia

plate (PP) overcomes the resistance of the spring and the striker pin hits the cap (PC).

The striker is attached to a convex disk of flexible metal forming a diaphragm (D). Upon impact the diaphragm deforms, reversing in shape and driving the striker pin (SP) against the cap (PC). A variation suitable for fast-moving warheads/missiles/bombs has the face of the diaphragm covered except for two small channels. Just before impact the air is compressed into these channels, acting upon the diaphragm as per direct impact with the solid target.

A heavy striker (HS) is held clear of the cap (PC) by a creep spring (S). On impact, inertia (the tendency of something that is moving to want to keep moving when it is suddenly halted) acting upon the striker causes it to overcome the resistance of the spring, allowing the striker pin to hit the cap.

The striker is retained by a thin metal flange or lip (F). On impact, inertia causes the striker to bend the retaining surfaces, allowing the striker pin (SP) to hit the cap (PC).

ELECTRICAL

A heavy contact (HC) is connected to one side of the circuit; the contact plate (CP) is connected to the other. The heavy contact is retained by insulated sprung jaws (SJ). Upon impact, inertia forces HC through the jaws and onto the contact plate, thereby completing the circuit.

The electrical switch comprises two thin plates (P) installed close together. On impact the point of a metal rod (MR) is thrust through the two plates, thereby completing the circuit.

The switch is fitted to the front of the warhead inside a crushable cover. On impact the two thin plates (TP) are forced together, thereby completing the circuit.

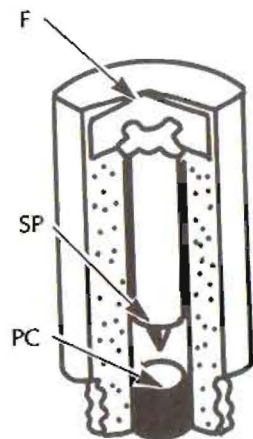

FIGURE 28:
Disk/flange retention

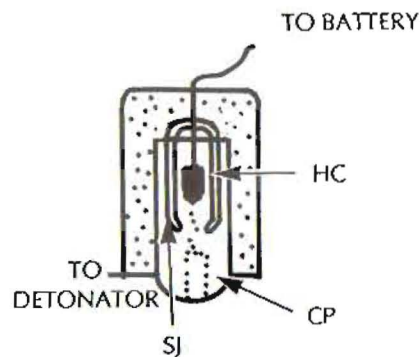

FIGURE 29: Inertia switch

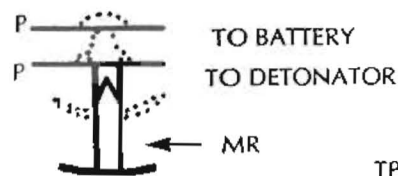
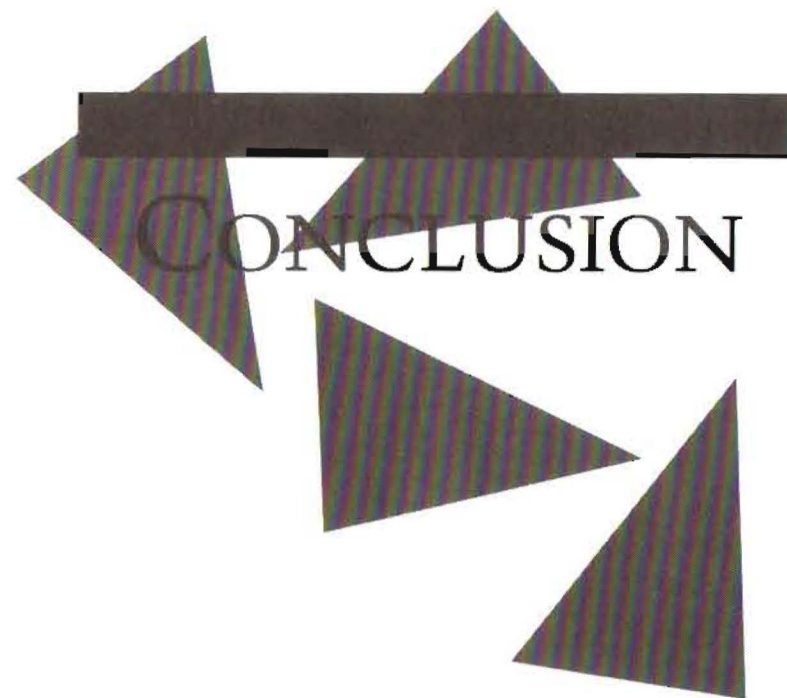

FIGURE 30: Thrust rod



FIGURE 31: Nose-switch



Take care when loading a rocket with a live improvised warhead. Remember the old anarchist's song, "If I drop this I'm fucking dead . . . de dum, de dum . . ."

Many thanks to "Nick," without whose help this project wouldn't have been possible. Good luck with the appeal, Nick; see you next visiting day.

Message to readers of Bic Farrall's book *Backyard Rocketry*: Bic has asked me to point out that the carrot-

shaped engine tubes on pages 7 and 49 are the result of his inability to defeat the computer graphics package monster from hell prior to publication. Yes, the tubes should be symmetrical. On a related note . . .

Rocket Man Is Jailed for Four Years

. . . A lovesick businessman who nailed a five-barrelled homemade rocket launcher to a tree intending to ambush his ex-lover's new boyfriend has been jailed for four years. . .

"X" first told the court that he rigged up the device to fire rockets into thunderclouds as an experiment. . . [then] changed his story and said the device was actually a suicide weapon. . . The judge described the case as "very strange" and said the (suicide) claim was "manifestly untrue and wholly implausible."

The moral of this true story? Christ knows, but it made me laugh.